



A Report on Field Visit to **ALL INDIA RADIO**

(27 January 2017)



On 27th of January, the students of MSc. and M. Tech., got a wonderful opportunity to observe real time working of the broadcasting process taking place at “**All India Radio**”. Total 22 students along with 2 faculty members had been to this field visit.

Our visit to the venue was welcomed, quite enthusiastically, by Mr. A. K. Shrivastav sir. He began the interaction by reminding us the motive of the visit. Later on he posed beautifully various challenges one should face while managing and operating such a communication process. He enlightened the students with the field associated job opportunities and work ethics. His whole presentation was based around a central theme of integrated working of studio, control room, studio transmitter link, receiver etc. He concluded the talk by sharing few incidences from his life. The session lasted for 1 hour.



After the session, we had been to see the transmitter room, STL tower, recording room and its working. We observed the working of professional mixing module.



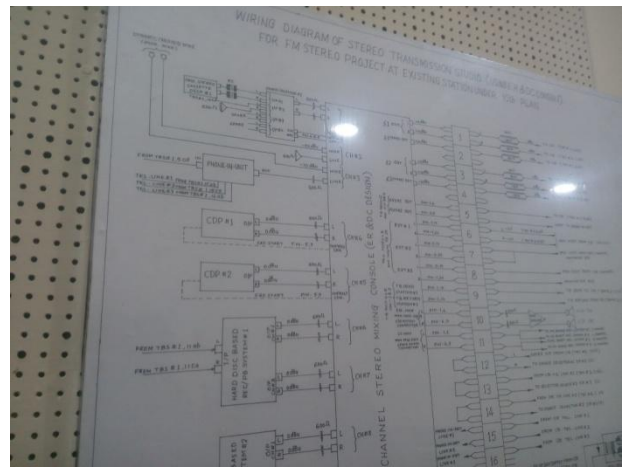
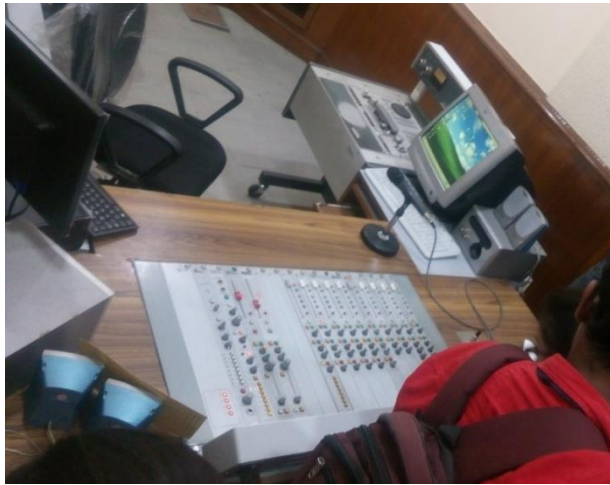

The figure above is of a professional module required for mixing. Since the *Aakashvani* is a type 3 recording studio, well equipped with all the facilities, it uses this type of module.

At the AIR office, we got to know that the broadcasting antenna is situated to a location few km away from there. There we learnt about the signal processing of the received audio signal and its power amplification prior to feeding it to mast type antenna. The antenna was matched to an impedance of 120 ohm by matching transformer. Here Mr. Lalit Sahu, assistant engineer, explained the signal mixing, processing and amplification. He concluded the talk by discussing to us, the project related opportunities at the site.

